

Inverter Driven Heat Pump

36,000 BTU Multi Position AHU

Job Name _____
 Location _____
 Engineer _____
 Submitted To _____
 Submitted By _____
 Reference _____

Date _____
 Approval _____
 Construction _____
 Unit No _____
 Drawing No _____

PRODUCT FEATURES

- Up to 1.0" WC
- 2-Wire Wired Remote Controls
- All Aluminum Coil
- Heating operation rated down to -5 °F outdoor temperature
- Long Lineset Lengths (up to 230')
- Integral Electric Heat Kit (Optional)
- Low Air Leakage Rate (2% or less)



MODEL NUMBERS			
Indoor Unit	AMUG36LMAS		
Outdoor Unit	AOUG36LMAS1		
System	36LMAS1		
EFFICIENCIES			
SEER	18		
SEER 2	17.1		
EER	11.3		
EER 2	10.7		
HSPF	10.2		
HSPF 2	8.8		
COP	kW/kW	3.22	
COP	Btu/hW	11	
COP2	kW/kW	3.2	
COP2	Btu/hW	10.9	
OUTDOOR TEMPERATURE OPERATION RANGE			
Cooling	°F(°C)		14 to 115 (-10 to 46)
Heating	°F(°C)		-4 to 75 (-20 to 24)
CAPACITIES			
Cooling	Rated	Btu/h	36000
	Min.–Max.		13,000–38,000
Heating	Rated	Btu/h	42000
	Min.–Max.		11,000–52,000
LINESET REQUIREMENTS			
Connection Method		Flare	
Liquid	in (mm)	Ø3/8 (9.52)	
Gas	in (mm)	Ø5/8 (15.88)	
Pre-charge length	ft (m)	98 (30)	
Minimum Length		16 (5)	
Max. length		230 (70)	
Max. height difference		98 (30)	
INDOOR DIMENSIONS & WEIGHT			
Net (H x W x D)	in (mm)	57 x 21 x 21- 11/16	
Gross (H x W x D)	in (mm)	57- 1/8 x 23 x 26- 1/2	
Net Weight	lb (kg)	132 (60)	
Gross Weight	lb (kg)	146 (66)	
OUTDOOR DIMENSIONS & WEIGHT			
Net (H x W x D)	in (mm)	39-5/16 x 38-3/16 x 14-9/16	
Gross (H x W x D)	in (mm)	45-12/16 x 41-14/16 x 18-13/16 (1,162 x 1,064 x 478)	
Net Weight	lb (kg)	198 (90)	
Gross Weight	lb (kg)	220 (100)	

Warranty Information



7 Year Compressor, 5 Year Parts out-of-the-box Warranty

10 Year Compressor, 10 Year Parts Warranty when registered within 60 days of installation in a residence

12 Year Compressor, 12 Year Parts Warranty when registered within 60 days of installation in a residence, and installed by a Fujitsu Elite contractor

ACCESSORIES

UTY-RNRUZ*	Wired Remote Controller
UTY-RSRY	Simple Remote Controller
UTY-RHRY	Simple Remote Controller
UTY-LBTUM	IR Receiver Kit with Wireless Remote Controller
UTY-XSZX	Remote Sensor Unit
UTY-XWZXZG	External Connect Kit
UTY-XCSX	External Input and Output PCB
UTY-XWZXZJ	Wire Kit
UTY-VTGX	Network Converter
UTY-TTRXZ1	Thermostat Converter

Due to continuous product improvements, specifications are subject to change without notice. Please log in to the Fujitsu Portal for the most up-to-date documentation <https://connect.fujitsugeneral.com>

Effective Date: 12/13/2022

Inverter Driven Heat Pump

36,000 BTU Multi Position AHU

FAN DATA			
Indoor Unit Airflow rate	Cooling	HIGH	1,200 (2,039)
		MED	740 (1,257)
		LOW	590 (1,002)
		QUIET	490 (833)
	Heating	HIGH	1,200 (2,039)
		MED	740 (1,257)
		LOW	590 (1,002)
		QUIET	490 (833)
Outdoor Unit Airflow rate	Cooling	2,590 (4,400)	
	Heating	2,590 (4,400)	
SOUND PRESSURE			
Indoor Unit	Cooling	HIGH	41
		MED	30
		LOW	27
		QUIET	24
	Heating	HIGH	40
		MED	35
		LOW	28
		QUIET	26
Outdoor Unit	Cooling	53	
	Heating	54	
REFRIGERANT			
Type			R410A
Charge	lb oz	9 lb 8 oz	
	g	4300	
Oil Type			POE (RB68)

ELECTRICAL SPECIFICATIONS			
Voltage/Frequency/Phase		208/230 V ~ 60 Hz	
Available Voltage Range		187–253 V	
Current	Cooling	Rated	14.8
	Heating	Rated	17
Maximum Operating Current	Cooling	A	32.4
	Heating		32.4
Starting current		20.1	
MCA		39.9	
Maximum Circuit Breaker		40	
Input Power	Cooling	Rated	kW
		Min.–Max.	
	Heating	Rated	
Power Factor	Cooling	%	98.7
	Heating		98.5
OTHER			
Moisture Removal	pints/h (L/h)	4.6 (2.2)	
Energy Star	No		
Drain hose	Material	LDPE	
	Tip diameter	in (mm)	Ø1/2 (13.0) [I.D.], Ø5/8 to Ø11/16 (16.0 to 16.7) [O.D.]
Operation Range	Cooling	°F (°C)	64 to 90 (18 to 32)
	Heating	%RH	–
Static pressure range	Cooling	°F (°C)	60 to 86 (16 to 30)
	Heating	inWG (Pa)	0.08 to 1 (20 to 250)

DIMENSIONS:

Units: In. (mm)

Indoor Unit:

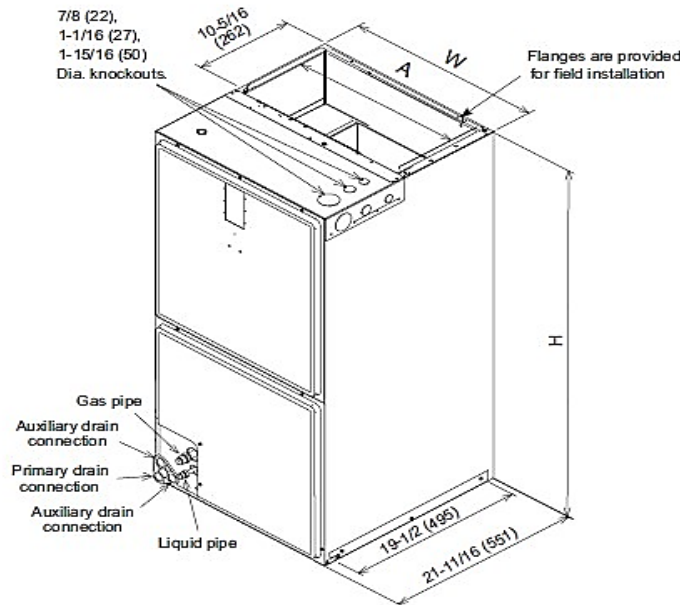

Model	A (Supply duct)	W (Unit width)	H (Unit height)
AMUG36LMAS	19-1/2 (495)	21 (533)	57 (1,448)

Return Opening Dimensions	
Width	Depth
19 3/8	19 3/4

